

Rear set for Kawasaki/ZX-10R/11-15



# RSK-10B

This set is pre-assembled. Remove the factory set, mount the brake pump, shifter rod and mount the ARP racing parts rear set in place of the original set. We recommend torquing the M8 screws to **20-22 Nm** and the M6 screws to **10 Nm** with the exception of the M6x10 ISO7380 screw (**21**) which only needs to be tightened lightly. **Over-tightening the screw (21) will result in damage of the brake joint pin (7).** We highly recommend using a low to medium strength threadlocker (our recommendation is Loctite 222). You are done, let's race!

**Make sure all the screws and nuts are tight!**

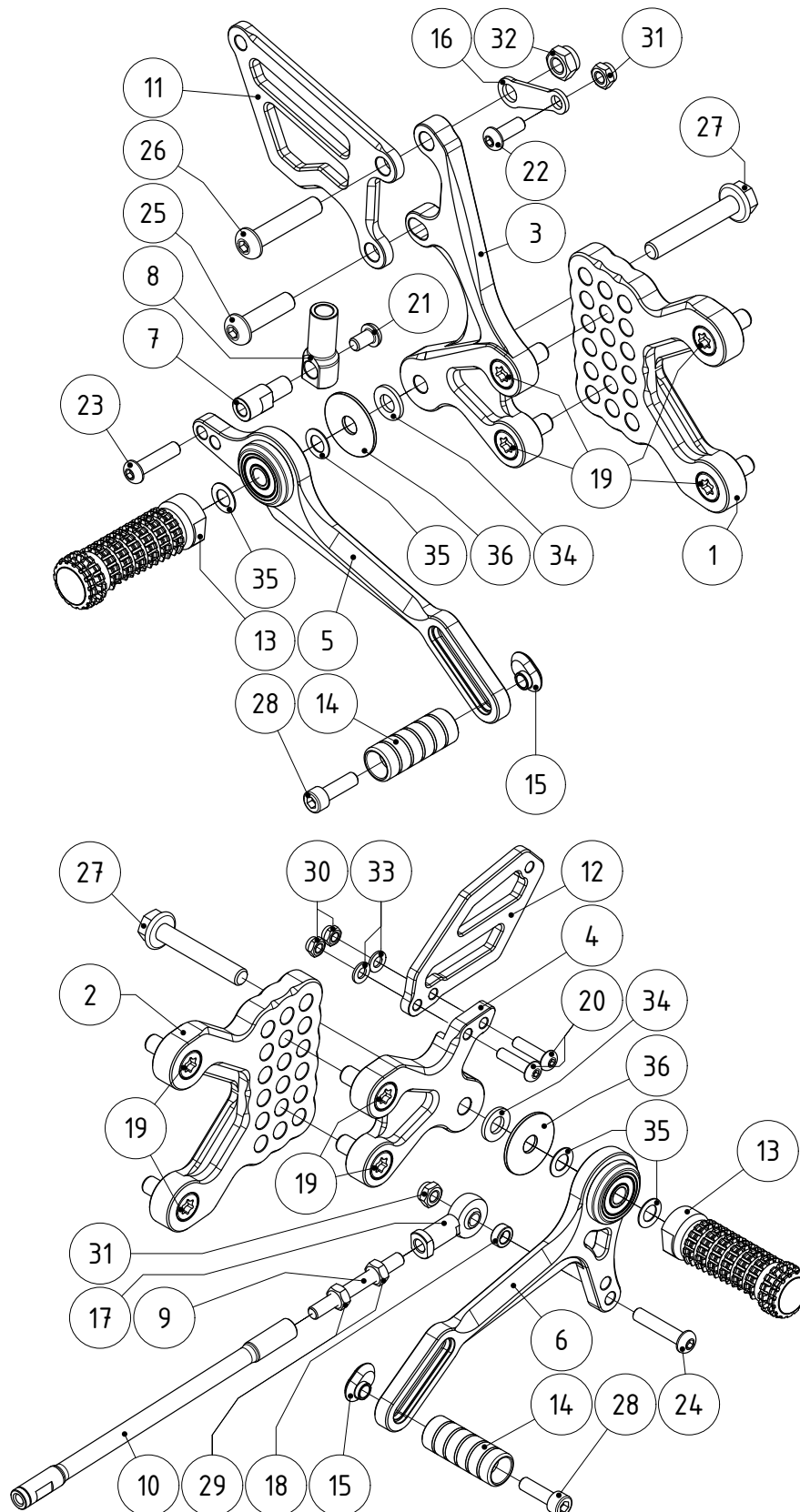

Position	Name	SKU (ordering number)	Qty.
1	Rear set base - right side	RSK-10-01	1
2	Rear set base - left side	RSK-10-02	1
3	Adjustable footpeg holder - right side	RSK-04-03	1
4	Adjustable footpeg holder - left side	RSK-04-04	1
5	Brake pedal (bearings incl.)	RSUP-01-10	1
6	Shift lever (bearings incl.)	RSUP-02-01	1
7	Brake joint pin	RSUP-09-026-15	1
8	Brake joint	RSUP-09-015	1
9	Shift rod extender 55mm	RSUP-04-07-55	1
10	Shift rod 185mm	RSUP-04-04-185	1
11	Heel guard - right side	RSUP-03-15	1
12	Heel guard - left side	RSUP-03-03	1
13	Footpeg*	RXU9001	2
14	Toe peg - fixed*	RSUP-09-005	2
15	Sliding nut	RSUP-09-006	2
16	Brake fluid reservoir holder	RSK-10-05	1
17	Joint ball female rod end	RSUP-07-007	1
18	Joint ball rod end spacer	RSUP-05-051	1
19	Torx low-profile socket head screw M8x20	M8X20 DIN7984	8
20	Rounded head screw M5x20mm	M5X20 ISO7380	2
21	Rounded head screw M6x10mm	M6X10 ISO7380	1
22	Rounded head screw M6x16mm	M6X16 ISO7380	1
23	Rounded head screw M6x25mm	M6X25 ISO7380	1
24	Rounded head screw M6x30mm	M6X30 ISO7380	1
25	Rounded head screw M8x30mm	M8X30 ISO7380	1
26	Rounded head screw M8x40mm	M8X40 ISO7380	1
27	Flanged hex head screw M8x50mm	M8X50 DIN6921	2
28	Socket head screw M6x20mm	M6X20 DIN912	2
29	Hex nut M6	M6 DIN934	2
30	Hex locknut M5	M5 DIN985	2
31	Hex locknut M6	M6 DIN985	2
32	Hex locknut M8	M8 DIN985	1
33	Washer 1x5x10mm	M5 DIN125A	2
34	Washer 1.6x8.4x16mm	M8 DIN125A	2
35	Stainless steel shim washer 0.5x8x14mm	0.5x8x14 DIN988 A2	4
36	Oversized washer 1.5x8.5x30mm	1.5x8.5x30 WSHR	2

Parts marked with \* can be replaced by other optional parts

Should any part suffer damage, it is simple to order a spare one. For convenience, use the [spare parts](#) section available on our website. This method ensures smooth and quick processing of your order without any hassle.

We base our rear sets on three key areas: functionality, durability and simplicity. The most important aspect is the functionality. They provide adequate ground clearance and essential feedback that is crucial for the rider to push the bike to the limit. We make our rear sets from 7075 billet aluminium, which provides exceptional durability and rigidity in comparison with the OEM rear set. In the event of a crash, the footpeg deformation zone acts as a slider. All that is required to change the footpeg is to undo one bolt. With simplicity and ease of repair in mind, our rear sets are made of the smallest number of parts possible.

## Footpeg position relative to the OEM footpeg

The picture below shows all available footpeg positions. Each numbered position corresponds to one table row. In the row, you will find the distance from the OEM footpeg in both directions.

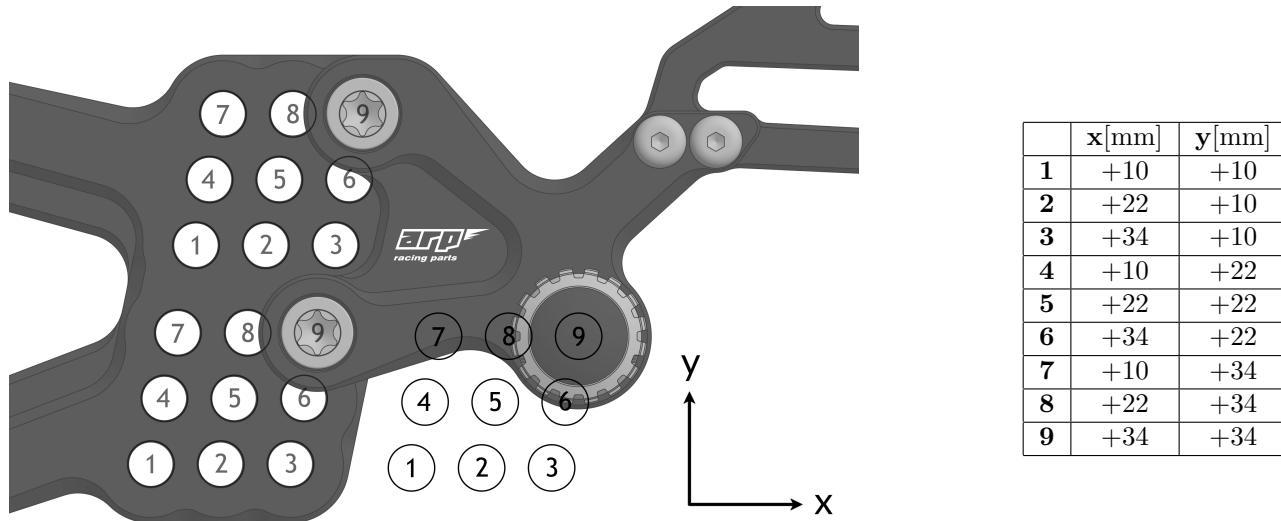

Please give us your feedback! We would be thrilled if you let us know about your experiences with our products. You can share your photos on our Facebook page or Instagram profile.

-  [facebook.com/arpracingparts](https://facebook.com/arpracingparts)
-  [instagram.com/arp\\_racingparts](https://instagram.com/arp_racingparts)
-  [twitter.com/arp\\_racingparts](https://twitter.com/arp_racingparts)

**Final inspection** before shipment. Product meets our highest standards and is in perfect condition.

Approved by: \_\_\_\_\_

Thanks for choosing ARP racing parts. Since delivering parts in perfect condition is our utmost priority, we are forced to add paper and plastic into packaging. We would, therefore, like to ask you to sort these materials into appropriate recycling containers. Thank you for helping us protect our planet.  
[arp-racingparts.com](https://arp-racingparts.com)

