

Rear set for BMW/S1000R/21-25



# RXB04R

This set is pre-assembled. Remove the factory set and mount the ARP racing parts rear set in place of the original set. We recommend torquing the M8 screws to **20-22 Nm** and the M6 screws to **10 Nm**. Make sure you tighten all of the parts after adjusting. We highly recommend using a low to medium strength threadlocker (our recommendation is Loctite 222). You are done, let's race!

**Make sure all the screws and nuts are tight!**

f

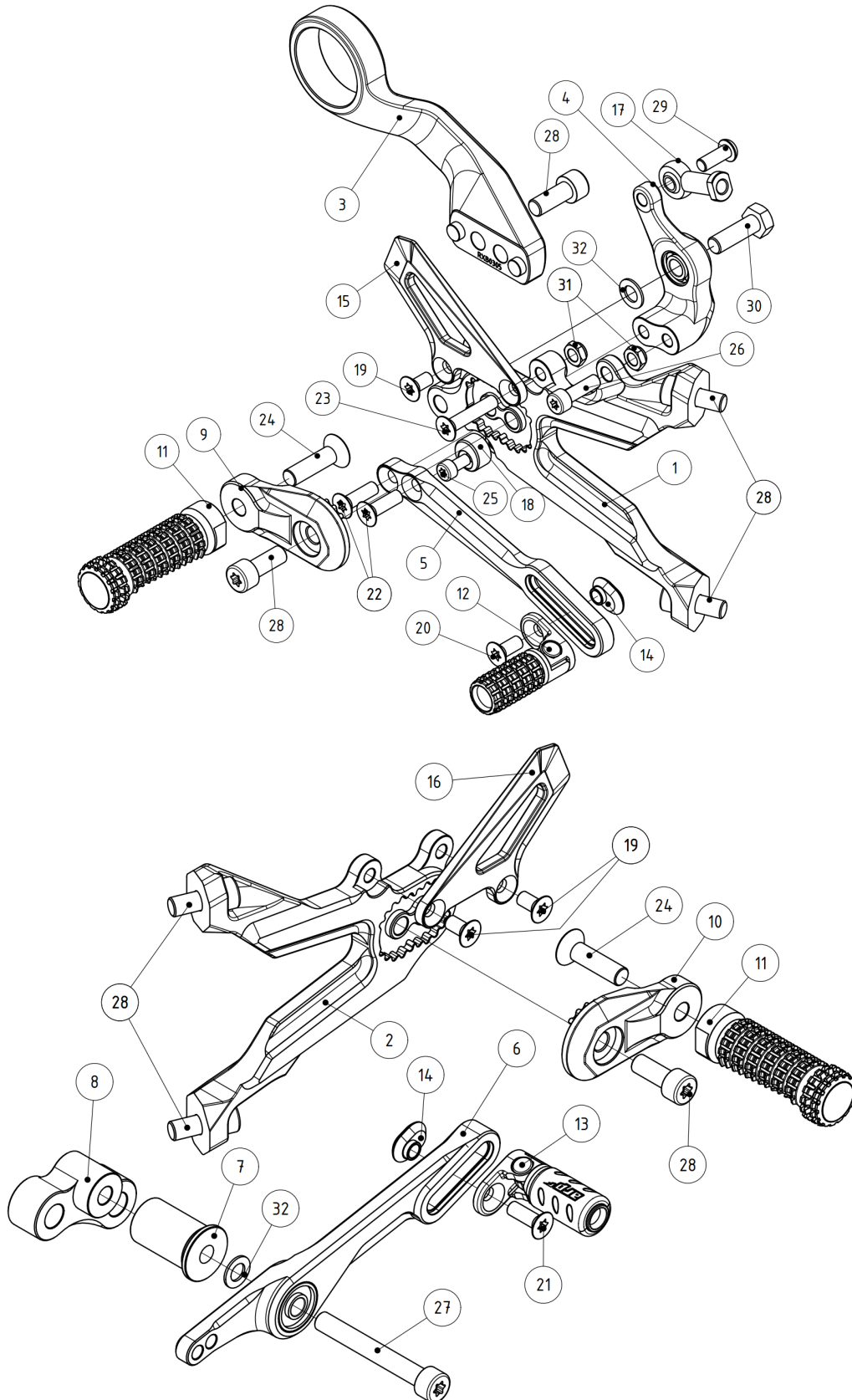

Position	Name	SKU (ordering number)	Qty.
1	Rear set base - right side	RXB0301	1
2	Rear set base - left side	RXB0302	1
3	Exhaust holder*	RXB0305	1
4	Brake lever part one (bearings include)	RXB0303	1
5	Brake lever part two	RXB0304	1
6	Shift lever (bearings include)	RXB0306	1
7	Shift lever spacer	RXB0310	1
8	Shift lever holder	RXB0307	1
9	Adjustable footpeg holder - right side	RXU9101R	1
10	Adjustable footpeg holder - left side	RXU9101L	1
11	Footpeg*	RXU9001	2
12	Folding toe peg - right side*	RXU9005-R	1
13	Folding toe peg - left side*	RXU9005-L1	1
14	Slider nut	RSUP-09-006	2
15	Heel guard-right side	RXU307	1
16	Heel guard-left side	RXU308	1
17	Joint ball female rod end	RSUP-07-008	1
18	Excentric washer	RSUP-09-080	1
19	Stainless steel torx flat head screw M6x12mm	M6x12 DIN7991 Tx A2	3
20	Stainless steel torx flat head screw M6x14mm	M6x14 DIN7991 Tx A2	1
21	Stainless steel torx flat head screw M6x18mm	M6x18 DIN7991 Tx A2	1
22	Stainless steel torx flat head screw M6x20mm	M6x20 DIN7991 Tx A2	2
23	Stainless steel flat head screw M6x35mm	M6x35 DIN7991 Tx A2	1
24	Stainless steel flat head screw M8x30mm	M8x30 DIN7991 A2	2
25	Stainless steel torx socket head screw M5x10mm	M5x10 DIN912 Tx A2	1
26	Stainless steel torx socket head screw M6x20mm	M6x20 DIN912 Tx A2	1
27	Stainless steel torx socket head screw M8x60mm	M8x60 Tx DIN912 A2	1
28	Stainless steel low profile socket head screw M8x20mm Tx	M8x20 DIN6912 Tx A2	6
29	Rounded head screw M6x16mm	M6x16 DIN7380	1
30	Stainless steel hex head screw M8x25mm	M8x25 DIN931 A2	1
31	Hex locknut M6	M6 DIN985	2
32	Washer 8x14x1.0	8x14x1.0 DIN988	2

Parts marked with \* can be replaced by other optional parts

Should any part suffer damage, it is simple to order a spare one. For convenience, use the [spare parts](#) section available on our website. This method ensures smooth and quick processing of your order without any hassle.

We base our rear sets on three key areas: functionality, durability and simplicity. The most important aspect is the functionality. They provide adequate ground clearance and essential feedback that is crucial for the rider to push the bike to the limit. We make our rear sets from 7075 billet aluminium, which provides exceptional durability and rigidity in comparison with the OEM rear set. In the event of a crash, the footpeg deformation zone acts as a slider. All that is required to change the footpeg is to undo one bolt. With simplicity and ease of repair in mind, our rear sets are made of the smallest number of parts possible.

## Footpeg position relative to the OEM footpeg

The picture below shows all available footpeg positions. Each numbered position corresponds to one table row. In the row, you will find the distance from the OEM footpeg in both directions.



	x[mm]	y[mm]
1	+10	+10
2	+24	+10
3	+10	+24
4	+24	+24
5	+10	+38
6	+24	+38

Please give us your feedback! We would be thrilled if you let us know about your experiences with our products. You can share your photos on our Facebook page or Instagram profile.

[facebook.com/arp\\_racingparts](https://www.facebook.com/arp_racingparts)

[instagram.com/arp\\_racingparts](https://www.instagram.com/arp_racingparts)

[twitter.com/arp\\_racingparts](https://twitter.com/arp_racingparts)

**Final inspection** before shipment. Product meets our highest standards and is in perfect condition.

Approved by: \_\_\_\_\_

Thanks for choosing ARP racing parts. Since delivering parts in perfect condition is our utmost priority, we are forced to add paper and plastic into packaging. We would, therefore, like to ask you to sort these materials into appropriate recycling containers. Thank you for helping us protect our planet.

[arp-racingparts.com](http://arp-racingparts.com)

